

**PRIMARY
PACKAGING**

PS 900

Vertical Packaging Machine

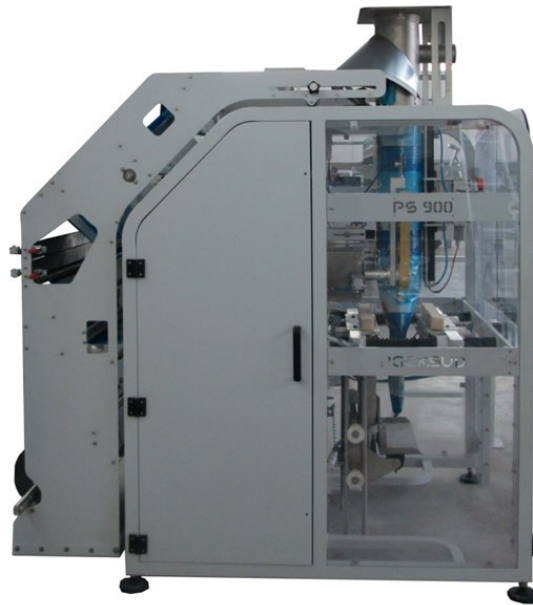

INDUSTRIES



STYLES

PILLOW



BLOCK BOTTOM



MULTIPACK

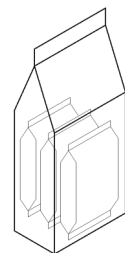

STANDARD FEATURES

The PS 900 intermittent vertical form fill and seal machine is designed to provide various packaging solution, for the food and non-food industry.

It is an electronically-pneumatically driven, compact, painted steel machine, with quick and simple change-over and maintenance.

PS 900 is designed and suitable for packaging large product formats.



Motorized film unwind

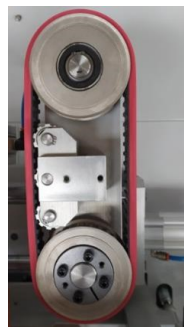

Pulling belts



Cross sealing



Vertical sealing bar

OPTIONALS

- **Pneumatic square bottom forming system**
- **Automatic print centering**
- **Automatic reel centering**
- **Motorized finished bag sliding plate**
- **Industry 4.0 compliance**
- **Eurohole**
- **Integrations with various weighing systems, code daters, labeling and clipping machines**

LAYOUT

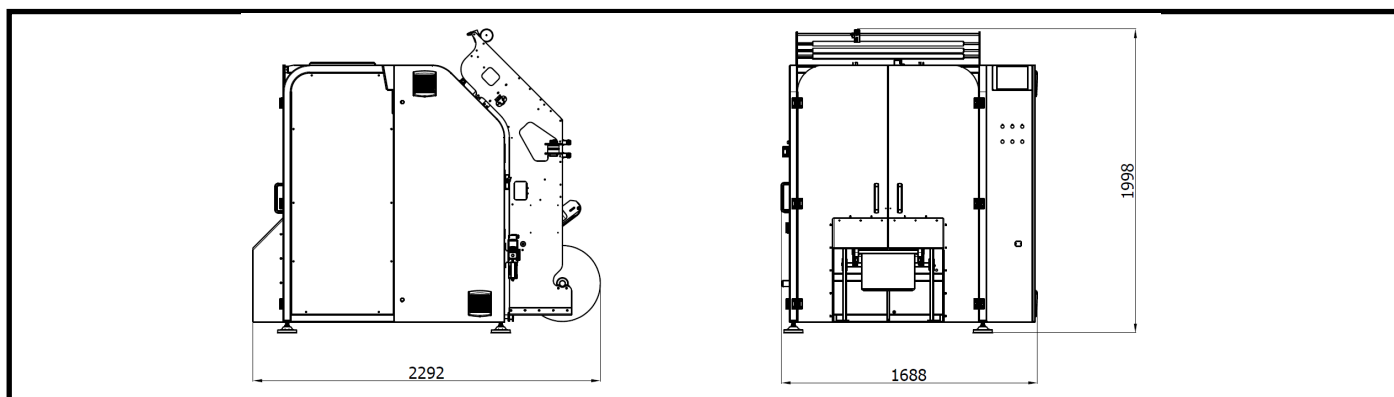

TOTAL WEIGHT	POWER REQ	AIR CONSUMPTION
550 KG	380 V - 50 Hz 4 kW	4,5 NL/cycle

TECHNICAL FEATURES

WRAPPING MATERIALS	Heat sealable materials, such as polypropylene, barrier films, laminates, as well as polyethylene films, paper films
ELECTRONIC PLATFORM	ALLEN BRADLEY

MAX REEL WIDTH	Ø FORMING TUBE	MAX BAG LENGTH	FLAT BAG WIDTH	Ø FILM REEL	MAX SPEED	SEALING JAWS MAX CLEARANCE
900 mm	Max. 280 mm	700 mm	430 mm	300 mm	40 cycles/min (dosing machine and product depending)	170 mm



SACMI Packaging & Chocolate S.p.A.
 Sede Legale: Via Selice Provinciale, 17/A - 40026 Imola (BO) Italy
 Sede Amministrativa: Via Trebbia, 22 - 20089 Rozzano (MI) Italy
 Tel. +39 0282452.1 - Fax +39 02 82452252
www.sacmi.it/chocolate www.sacmi.it/packaging